

BYOC Filter Kit Instructions

Parts Checklist.....	page 2
Populating the Circuit Board.....	page 3 - 6
Assembly.....	page 7
Mounting the PCB.....	page 8 - 10
Wiring.....	page 11
Schematic.....	page 12
Finish up.....	page 13

Parts Checklist for Envelope Filter Kit

Resistors:

- 1 - 2.2k (red/red/black/brown/brown)
- 1 - 4.7k (yellow/purple/black/brown/brown)
- 3 - 10k (brown/black/black/red/brown)
- 3 - 22k (red/red/black/red/brown)
- 3 - 100k (brown/black/black/orange/brown)
- 3 - 220k (red/red/black/orange/brown)
- 1 - 430k (yellow/orange/black/orange/brown)
- 1 - 1M (brown/black/black/yellow/brown)
- 1 - 2.2M (red/red/black/yellow/brown)

Capacitors:

- 1 - .01uf film (103 or 10nJ)
- 2 - .022uf film (223 or 22nJ)
- 1 - .047uf film(473 or 47nJ)
- 3 - 0.1uf film (104 or 100nJ)
- 1 - 1uf aluminum electrolytic
- 1 - 4.7uf aluminum electrolytic
- 1 - 10uf aluminum electrolytic
- 1 - 100uf aluminum electrolytic

Diodes:

- 2 - 1N914 or 1N4148
- 1 - 1N4001

IC's:

- 4558 or other dual op amp

Opto-Coupler:

- VTL5C4/2

Potentiometers:

- 3 - A100k log PCB mounted

Hardware:

- 1 - drilled enclosure w/ 4 screws
- 1 - byoc filter kit circuit board
- 1 - 3pdt footswitch
- 1 - spdt toggle switch (envelope/manual)
- 3 - knobs
- 1 - AC adaptor jack
- 1 - 1/4" stereo jack
- 1 - 1/4" mono jack
- 1 - battery snap
- 1 - red LED
- hook-up wire

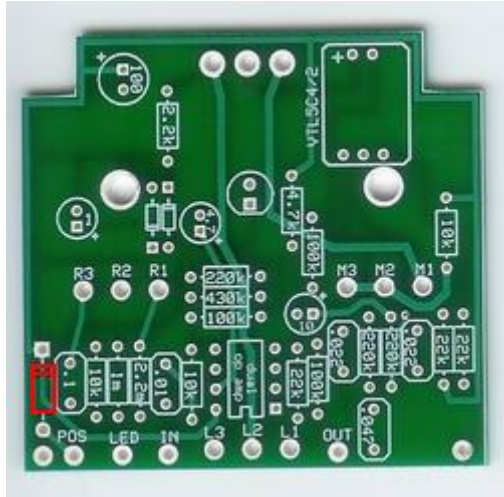

Step 3: Add the larger black plastic diode with silver stripe(1N4001). Make sure the stripe matches up with the layout on the PCB. The cathode(striped end) goes in the square solder pad. The anode goes in the round solder pad.

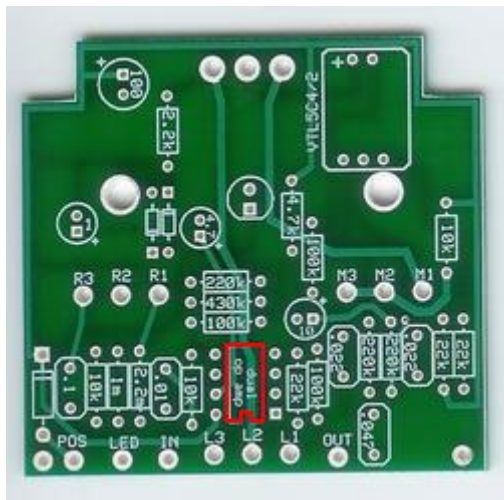

Step4: Add the Op Amp. Pin 1 of the op amp will go in the square solder pad. Pin 1 is sometimes denoted by a small dot in one corner on the top of the chip. This dot should be in the same corner as the square solder pad on the PCB. Sometimes there will also be a U-shaped notch in one end. Match this notch up with the notch in the layout. Usually there is only one type of marker or the other for orienting the OpAmp, but if there are both markers, always defer to the U-shaped notch first.

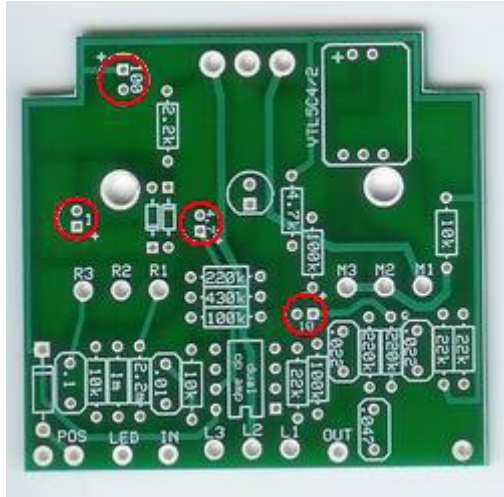

Step 7: Add the aluminum electrolytic capacitors. These will be the can shaped caps. They are polarized so make sure to orient them correctly. The longer lead is the positive lead and goes in the square solder pad. The shorter lead is the negative lead and goes in the round solder pad. The negative lead will be denoted by a stripe or some sort of marker running down the side of the capacitor.

Assembly

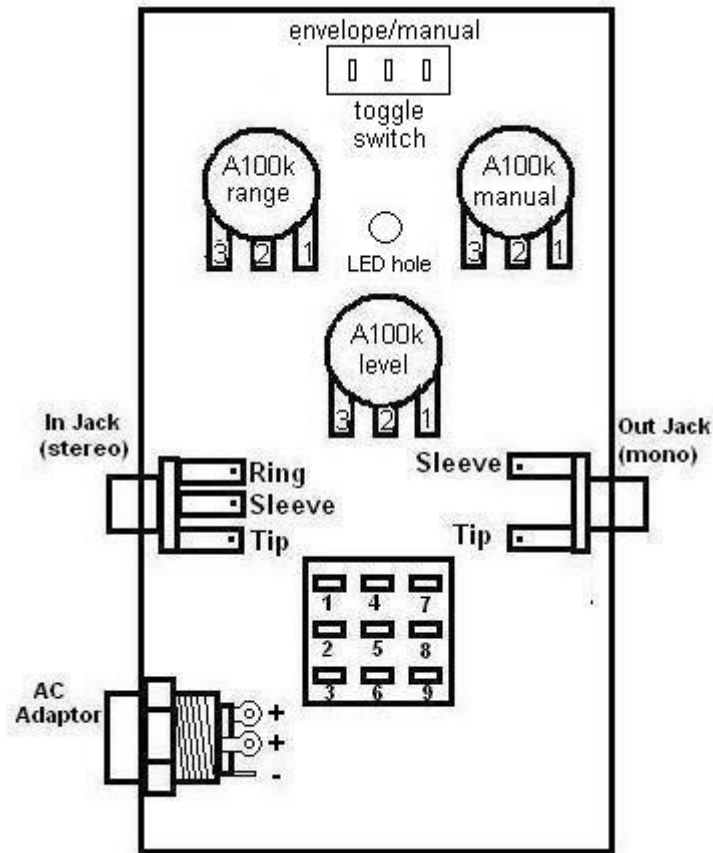

1. Install the jacks first. If you are looking down inside the enclosure, the mono jack goes on the right side and the stereo jack goes on the left. Place the washer on the outside of the enclosure. Use a 1/2" wrench to tighten
2. Install the AC adaptor jack. The bolt goes on the inside. Use a 3/4" or 14mm wrench to tighten
3. Install the potentiometers so that the solder lugs are pointing down. The washers go on the outside. Use a 10mm wrench to tighten but only snug. Do not over tighten the pots. You should leave the pots somewhat loose until they are soldered to the PCB so that it will be easier to mount them.
4. Install the toggle switch. The toggle switch will come with a notched washer that should be removed. One nut goes on the inside of the enclosure. The serrated washer and other nut go on the outside. Leave the outside nut slightly loose until it is soldered to the PCB. Only snug tight after solder
5. Install the footswitch. The first bolt and metal washer go inside. The plastic washer and second bolt go on the outside. It does not matter which side you designate as the "leading edge" of the footswitch as long as you orient it so that the flat sides of the solder lugs are aligned in horizontal rows, not vertical columns.

Mounting the PBC

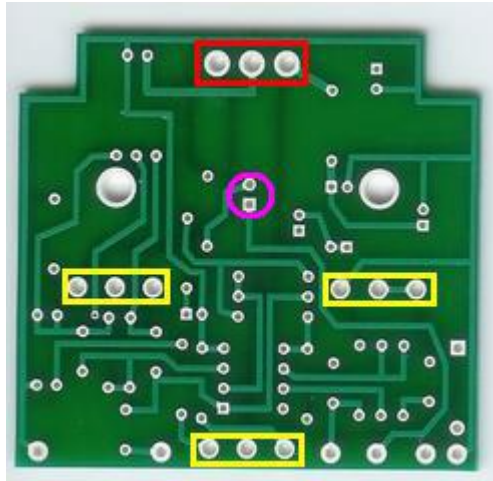

Step1: Understand that the LED, all 3 potentiometers, and the toggle switch will be mounted and soldered directly to the underside of the PCB. The LED will go into the eyelets highlighted in purple. The potentiometers will go into the eyelets highlighted in yellow. And the toggle switch will go into the eyelets highlighted in red. Read through all the steps in this portion before doing anything so that you can get the “big picture”.

Step 2: **Install the LED but do not solder it or clip the leads.** You will insert the LED into its eyelets. Make sure the longer lead goes in the round eyelet and the shorter lead goes in the square eyelet. Yes this is correct! Longer lead in the round eyelet. Shorter lead in the square eyelet. Now bend the leads of the LED so that it will not fall out of the PCB when you flip it over.

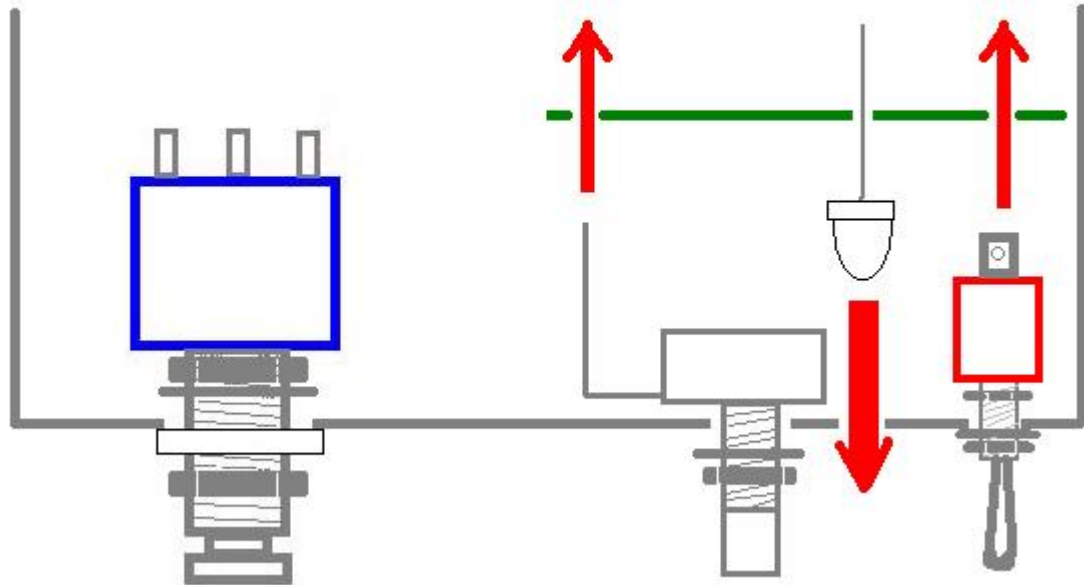

Step 3: Now mount the PCB with LED onto the leads of the toggle switch and the potentiometers. This move may take a little finesse. It's best to leave your toggle switch and pots somewhat loosely mounted to the enclosure so that you can easily move them to line up with the eyelets on the PCB. You may need to bend the leads of the pots into place if they were bent in shipping.

Step 4: once you have the PCB in place, snug the nuts of the pots and toggle switch with your fingers.

Step 5: Move the LED into place by guiding it with the leads that are sticking out of the top side of the PCB.

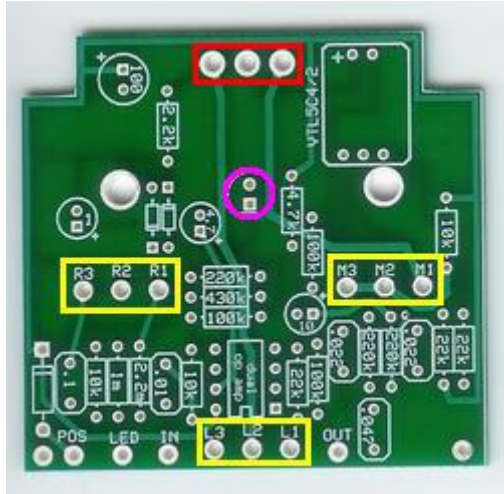

Step 6: Solder the LED, toggle switch, and pots on the top side of the PCB. Clip the excess LED leads. Do not clip the leads of the pots or toggle switch.

Schematic

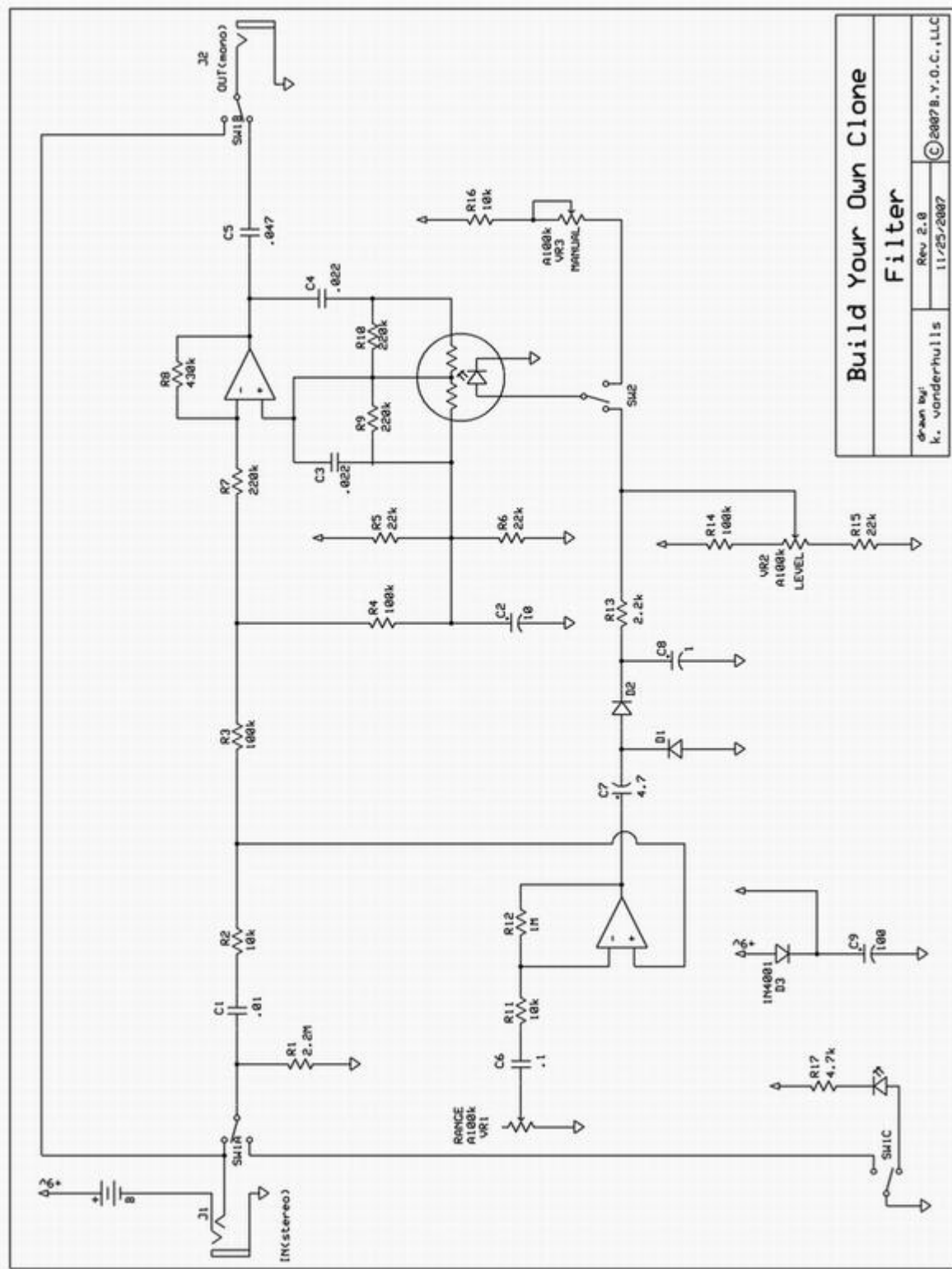

**Build Your Own Clone
Filter**

drawn by:
k. vanderhulst

Rev 2.8
11/25/2007

©2007 B.Y.O.C., LLC

Finishing Touches

Install the base of the enclosure with the 4 screws that came with your kit. Add the rubber bumper feet...unless you're a velcro person. Add the 3 knobs. Be sure not to tighten the set screw too tight or you may strip them. Remember that the toggle switch to the left is envelope mode and to the right is manual (fixed wah) mode. If you've got any problems that you can't figure out yourself, visit board.buildyourownclone.com for technical support